

<sup>1</sup> Lech MAZUREK, <sup>2</sup> Antoni ŚWIC, <sup>3</sup> Marian Marek JANCZAREK

## INCREASING THE ELASTICITY OF MULTITASKING MACHINING USING TOOLING FOR TOOLS AND WORKPIECE CLAMPING IN A CNC MACHINE TOOL

<sup>1</sup> THE STATE SCHOOL OF HIGHER EDUCATION IN CHELM, POCZTOWA STR. 54, 22-100 CHELM, POLAND

<sup>2,3</sup> LUBLIN UNIVERSITY OF TECHNOLOGY, INSTITUTE OF TECHNOLOGICAL SYSTEMS OF INFORMATION, NADBYSTRZYCKA 36, LUBLIN, POLAND

**ABSTRACT:** The article presents rules for designing a device for fastening tools and machined parts to a CNC machine tool. Suggested tooling was used on machine tools already working in machining industry. Those machine tools can be elements of Flexible Production Systems. Presented solutions facilitate the application of CNC machine tools in low-volume and piece production.

**KEYWORDS:** workpiece, tool, fastening, CNC machine tool setting

### INTRODUCTION

Flexible production systems (FPS) are integrated, computer-controlled machines and appliances of numerically controlled, technological measuring, transporting and machining systems, designed to manufacture products of desired class in a specific order, the appliance of which is limited by the number and diversity of the product.

In mass or, more visibly, in low-volume production, a considerable part of manufacturing cycle time is not occupied by the machine time but such processes as: total tools re-setting time, the time of FPS subsystem restoration after failure as a result of functional or parametric failures, awaiting semi-finished products and their transport. This is a typical drawback of FPS.

That is why, basing on the classification of CNC machine tools efficiency and reliability improving methods, the article will discuss constructional solutions for setting and fixing the workpiece and the tool.

### THE CLASSIFICATION OF CNC MACHINE TOOLS EFFICIENCY AND RELIABILITY IMPROVING METHODS

The classification of CNC machine tools efficiency and reliability improving methods includes following types of operations:

- internal – conducted only after stopping machine,
- external – conducted while machine is working.

The most important part of machine re-setting is to [3, 5, 6]: separate internal and external operations (transport and switching tools and instruments), substituting internal operations with external operations (preparing the machine tool in advance, standardization of tools and devices assembly, reducing the application of mediating devices) as well as optimization of preparatory operations:

- optimization of external operations, i.e. storing and transport of exactly specified quantity of tools, devices and materials prepared for consecutive operations,
- optimization of internal operations, i.e. using fast mounting devices, elimination of manual adjustment, mechanization of some preparatory operations, carrying out preparatory operations simultaneously by two people.

Preparatory operations time is yet another element that will have a significant effect on the improvement of the FPS. The aforementioned preparatory operations include:

- setting, placing and adjusting tools,
- setting, placing and adjusting machining devices.

### TECHNOLOGICAL METHODS CONCERN CONDUCTING PREPARATORY OPERATIONS IN A PRODUCTION PROCESS

#### Setting a CNC machine tool with a programme placing the device-retaining element

In this method of machine tool setting [1, 4, 7], the placing of the device retaining element, which determines the last cell of the appropriate device measurement chain, takes place directly on the CNC machine tool following a special program, within the operating technological process setting outline. The method relies on the possibility of compensation for the device measurement mistakes chain by means of arranging the element directly retaining the workpiece with a special program. It is therefore unnecessary to take measurements of the actual location of retaining elements (clots, tiles). There is, moreover, no need to adjust the steering program, basing on the measurements. In addition, application of this method simplifies the construction of the body of the device (bases, stab) as a result of the elimination of retaining elements placing holes.

**Setting a CNC machine tool relatively to the measuring base changing its location in the system of coordinates of the machine tool**

The suggested method enables setting the machining tool relative to every measuring base changing its location in the system of coordinates of the machine tool. Additionally, it prevents from machining parts of surfaces that are not to be machined. In addition, this method expands technological possibilities of a multitask CNC machine tool by reducing the number of parts settings while changing the setting base. It also lets the CNC machine perform operations that, in the past, were carried out, following the test passages method, on universal machine tools.

This method does not require any devices to regulate external tools, since it is possible to programme them from the level of the machine, without applying additional position sensors.

**Setting a CNC machine tool in relation to a moving base**

This method is designed for automatic adjustment of multitask CNC machine tools, both single axis, as well as multi axis ones, working autonomously as well as in flexible production systems on universal machines. This method aims at increasing the placing accuracy and placing processing parts by eliminating the mistake of placing the retaining element.

**STRUCTURAL METHODS**

These methods are connected with the construction of the machine tool, machining tools and mounting parts and consist in substituting internal operations with external ones – preparing the machine tool in advance.

**Setting the workpiece relatively to a bottom surface of a T slot locating face**

The device is designed to set the workpiece in a multitask CNC machine tool working in FPS and to reduce the re-setting time for machining a workpiece of another kind. [3, 5]

**Setting a workpiece relatively to the top surface of a T slot locating face**

The tool may be used as an universal device for setting parts in multitask CNC machine tools, working individually or as a part of FPS. The aim of its workings is to improve precision of setting parts and to lower labour intensity. In the suggested method, in comparison to the one presented in [2, 5], the action of the ring on the bottom of a T slot during the movement of the retaining element is abandoned. This results in improved precision of fixing and shortened re-setting time. Additionally, owing to broadened tolerance range, the preparation of slots is facilitated. The device consists of a locating face, 1, with T slots, 2, (Figure 1.) and retaining elements, 3, fixed in the slots. The locating face has an initial position, 4, and the

base surface, 5. Each retaining element, 3, consists of a ring, 6, with a disk, 7, and a thrust element, 8, so a nut located in the thread of a ring, 6, and freely set on the spring collet, 9, with a chamfer Z, the thrust ring, 10, and a set of disk springs, 11.

Between the disk, 7, of the ring, 6, and the bottom G of a T slot there will be a space S, and the thrust ring, 10, interacts with surface I of a T slot, 2, opposite the bottom, G, of the slot.

Retaining elements, 3, in slots, 2, are moved by the socket, 12, supplied with thrust splines, 13, and a fixing axle, 14, with a lead-in chamfer M. There is a T slot, 15, in the fastening position, the vertically extended part of which is bigger than the height of the vertically extended T slots, 2, of the grid. The locating face, 16, is placed on the base surface 5.

The re-setting procedure takes place as follows:

The coordinates of the machine tool need to include the coordinates of part 17 (Figure 1). Therefore, it is necessary to set the retaining elements, 3, in proper operative positions of the slots, 2. The operative readiness of retaining elements is achieved by correcting consecutive errors by the means of nuts, 8 (Figure 1 and 2):

$$(K+D) < (H+B),$$

$$(B > D), \text{ while } (B - D) < e \cdot n,$$

where: K – the height of an unpressed set of disk springs and a thrust ring; T – the distance in the fastening position, from the base surface to the thrust ring; H – height of an extended part of a T slot, 2; B – the size from the base surface to the extended part of a T slot, 2; e – maximum permissible pressing of a disk ring; n – the number of disk rings in a set.

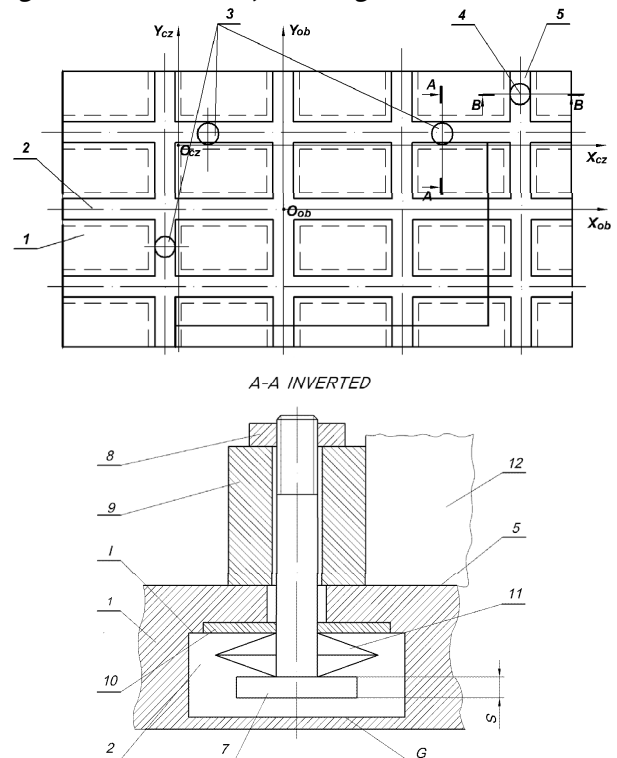

Figure 1. A retaining element

The prepared retaining element moves into fastening position at the same time, the chamfer of the base socket, 9, is set in a locating face, 16, what ensures required corner location of chamfer B (Figure 1 and Figure 3). The set of disk springs, 11, is unpressed, so  $H_1 > H$ . Consequently, according to the programmed instructions, a spindle, let it be with socket 12, approaches the fastening position 4.

The spindle axis with the socket are compatible with the retaining element axis, 3, at the same time oil supplied into the hydraulic cylinder of the socket exerts such a pressure that moves the axle 14 to the right (Figure 3). The spindle with the socket lowers, the retaining element, 3, enters the thrust axle inlet, 14 (Figure 4). The thrust splines, 13, pressing the thrust ring, 10, press the set of disk springs 11 (Figure 2 and Figure 3). Next, clamping the retaining elements in socket 12, results in dropping the oil pressure in the socket cylinder and the wedging axle 14, pressed by disk springs, moves to the left, wedging the collet 9 (Figure 3).

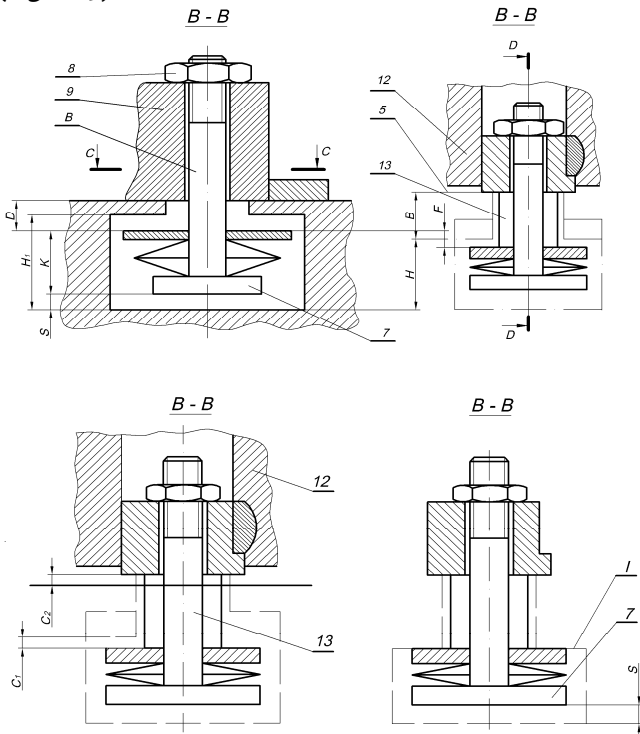

Figure 2. B-B Cross-section Figure 1 (after re-setting the retaining elements)

The spindle with the retaining element clamped in socket, 12, moves up along the axis in order to keep the spaces between the bottom face surface of the base socket 9, and the the base surface 5, of the clamping face 1, as well as between the T slot locating face 2, and the thrust ring 10 (Figure 2). In such a position the spindle with the retaining element moves along the T slot 2, according to the coordinates of the machine tool (Figure 2) into the required position, setting the system of coordinates (Figure 1). In this position, the oil is supplied into the socket, 12, cylinder releasing the base collet.

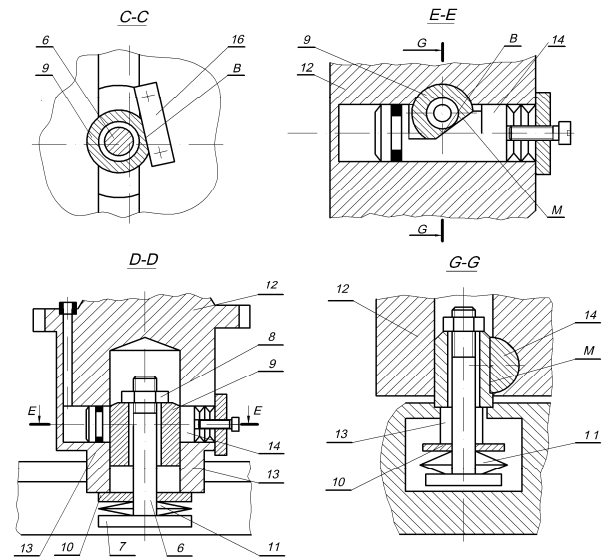

Figure 3. C-C and D-D cross-sections in the Figure 2., E-E and G-G cross-sections

**Device for clamping rotational tools and retaining elements relative to processing part moving base**

This device may be applied to multitask CNC machine tools with a view to automated clamping of the tools with an automated tuning of the tool outlet relative to a moving base, as well as for an automated clamping the retaining elements in a socket (Figure 4.). The device consists of the casing, 1, the shank of which is clamped in the machine tool spindle. There are two longitudinal unthrough holes in the casing, 2 and 3, and two transverse ones, 4 and 5, intersecting the longitudinal. The casing, 1, holds also inlet channels 6, 7, and 8, providing hydraulic pressure in the outlets at the ends of holes 3 and 4, where the rams, 9 and 10, are fixed. At the one end of the rams 9 and 10, there are seals 11 and 12, and on the other end disk springs 13 and 14, washers 15 and 16, as well as screws 17 and 18 adjusting the pressure of the disk springs. Seal 11 prevents oil leaks after casing-spindle joint. Longitudinal, 2, and transverse, 5, holes hold springs, 20, designed to interact with face surfaces of tools 21 and 22, or with retaining elements, the chamfers of which, 23, interact with the ones on the rams, 24.

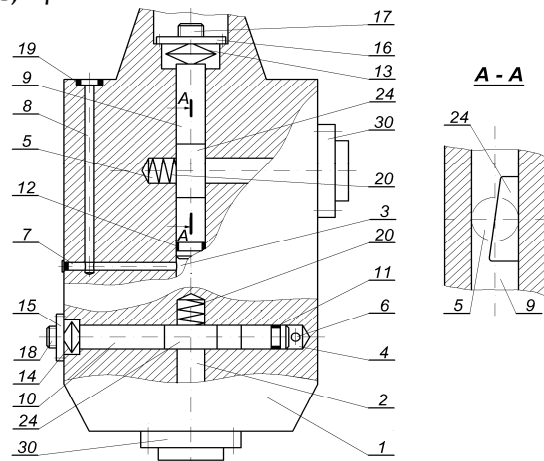

Figure 4. The device and its cross-section on an A-A surface

Figure 5 presents a retaining element and its longitudinal section. The retaining element has a shank, 25, identical to the shank of the tool. The shank of the retaining element holds also a washer, 26, and a ring 27, with disk rings, 29, fixed between them with a screw. The casing holds thrust sockets, 30, fixed coaxially to the holes 2 and 5.

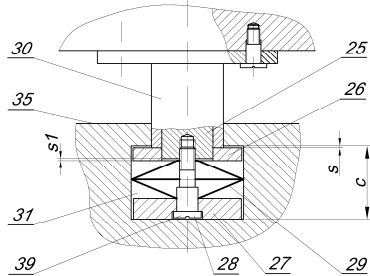

Figure 5. Retaining element and its longitudinal section  
 As the movement of the spindle along the retaining element axis continues, thrust socket 30 presses thrust ring 26, pressing at the same time the set of disk springs, 29, with a value Z. As soon as there is an adequate space between ring 26 and T slot locating face 31, shank 25 is clamped in hole 5. The pressure in hydraulic system drops and, as a result of the pressure from disk springs 13, ram 9 moves towards hole 3 fixing the retaining element in the device.  
 Figure 6 shows the device with an end mill fixed - a), the device with a bar holder fixed - b);

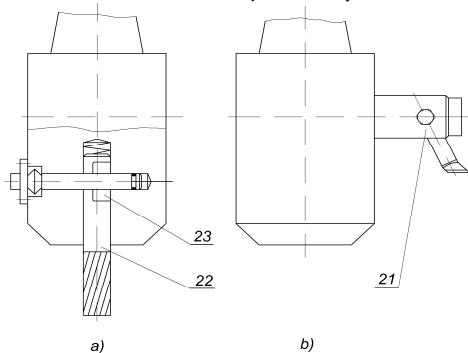

Figure 6. The device with an end mill fixed -a); the device with a bar holder fixed -b);

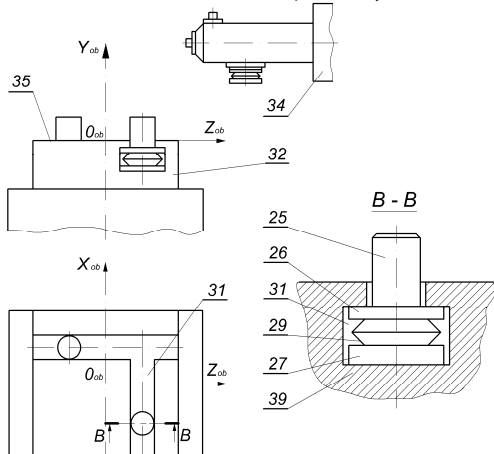

Figure 7. The diagram of setting retaining elements in a locating face or a pallet. The base locating surface, parallel to the spindle axis - a), retaining element clamped in a T slot of the tool or the pallet - b);

Figure 7 shows the diagram of setting retaining elements in a locating face or a pallet. The base locating surface, parallel to the spindle axis - a), retaining element clamped in a T slot of the tool or the pallet - b);

The firmness of the clamp is provided by chamfer 24 and an appropriate truncation, 23, on the retaining element.

According to the programme, the spindle moves the retaining element along T slot 31 and further, into the desired position set by the machine tool system of coordinates  $X_{ob}$   $O_{ob}$   $Z_{ob}$ .

Once again, the oil is supplied into the hydraulic system of the device, ram 9 moves away from the shank of the retaining element and, released from the pressure from the set of 29 disk springs, is fixed into the T slot of the pallet or of the device (Figure 5, Figure 7)

Figure 8 shows the diagram of setting retaining elements on a V-block device, the base surface of which is perpendicular to the spindle axis -a), schematic machining of a workpiece -b);

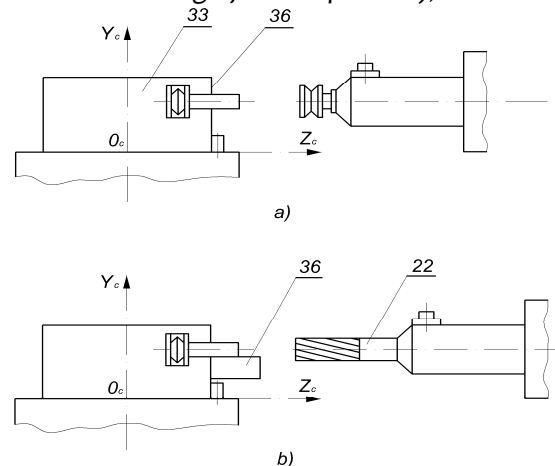

Figure 8. The diagram of setting retaining elements on a V-block device, the base surface of which is perpendicular to the spindle axis-a), schematic machining of a workpiece-b)

Figure 9 shows: The diagram of mutual initial positions of the device and retaining element -a), retaining element in the device -b), retaining element movement diagram -c);

Then, following the programmed sequence, the spindle with the device moves perpendicularly to the locating surface 35, away from the retaining element. The following conditions need to be met (Figure 13):

$$H_z = (A_{z0} - A_{z1}), B = A_{z1},$$

where  $A_{z0}$  – the distance between the spindle axis and the bottom surface, 37, of a T slot 31, and the initial position.  $A_{z1}$  is the length of a programmed movement of the spindle with the device with disk springs of the retaining element pressed to value Z; W – is the distance between ring 27 of the retaining element and the bottom of a T slot while relieving the spindle with a fixed retaining element into the initial position.

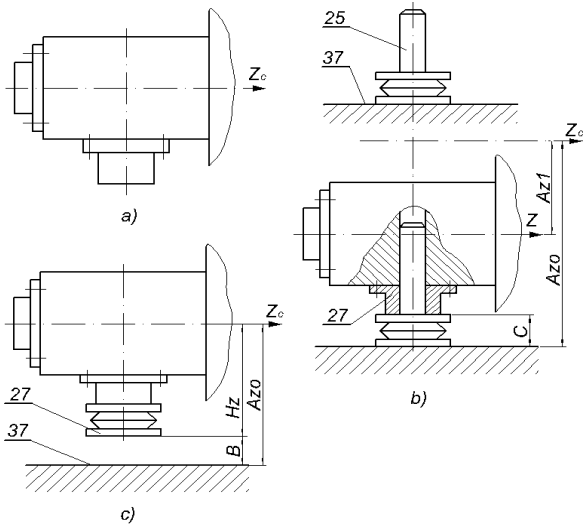

Figure 9. The diagram of mutual initial positions of the device and retaining element -a), retaining element in the device -b), retaining element movement diagram -c)

Having set the retaining elements in the machine tool set of coordinates  $Y_{ob}O_{ob}Z_{obr}$ ,  $X_{ob}O_{ob}Z_{ob}$  (Figure 1), their clamping elements in T slots set and fix workpiece 38 or 39, which is then machined according to the programme (Figure 6, Figure 8).

Other retaining elements are set accordingly (Figure 7, Figure 8). While fixing retaining elements the axis of which is parallel to the spindle axis (Figure 8a), another pair of mutually perpendicular holes, 2 and 4, of the casing is used (Figure 4). In such a case, the workpiece (38) is set in a base clamping surface, 36, perpendicular to the spindle axis.

Thrust sockets after re-setting the device, may, if required, be removed from the casing, 1. The device may be then used for automatic fixing and removing the cutting tool, 22, e.g. a shank cutter from socket 21, (Figure 6). Fixing the cutting tool is the same as in case of fixing the retaining tool.

Figure 10 shows a model machining of a workpiece 39 – milling with a cutter 22, and boring with a boring cutter 21.

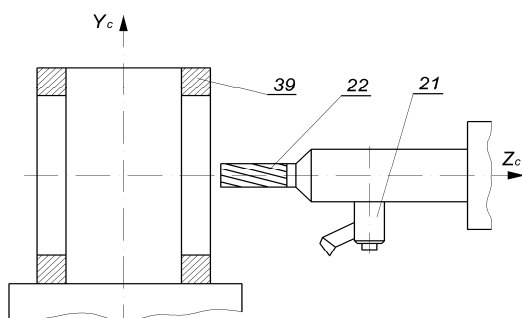

Figure 10. Machining scheme

**Device for automated fastening shank tools**

The device is designed to use with the CNC machine tools, improves and expands technological possibilities during setting the shank outlet relative to every processing part moving base or the device itself. Figure 11 introduces the device set relative to the tool outlet and clamped in spindle's socket.

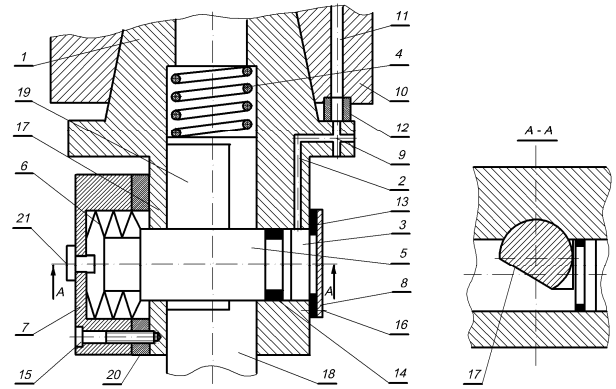

Figure 11. Socket regulating Az a tool outlet

The device is composed of (Figure 11): a tool socket, 1, with channels, 2, supplying oil to the space, 3, of the spring, 4, closing axle, 5, disk springs, 6, a shell-case 7, the cover 8, a return valve 9.

The device is set in the spindle's cone, 10, with an oil-supplying channel, 11. Gaskets 12 – 14 prevent any oil leaks. The shell-case and the cover are secured with screws 15 and 16. The closing axle, 5, has a chamfer 17, adjusting the tool, 18, with a proper cutting, 19, on its end. The required tool clamping power is achieved by the right ring thickness, 20. A thrust screw, 21, limits the jump of a closing axle, 5, therefore prevents the machining tool jumping off into a not clamped state. During setting, machining tool outlet runs into the moving base, 22, of the workpiece (or of the device) 23, placed on the CNC machine table 24 (Figure 12).

Figure 12. shows setting the machining tool outlet pattern, where:  $z_0$  - the distance of the spindle front surface from the table surface in the initial position ("o" for the machine tool in relation to Z axis);  $A_z$  - the measurement along the spindle axis, set from moving base, 22, to the spindle front surface (tool outlet);  $z_1$  - value of movement of the spindle with tool after setting the tool outlet; K - the spring, 4, pressing value assuring the guaranteed contact of the machining tool outlet with the measurement moving base;  $z_2$  - the distance between the fastened machining blade and the moving base with a spindle in the initial position ("o" for the machine tool), while  $z_2 = z_1$ .

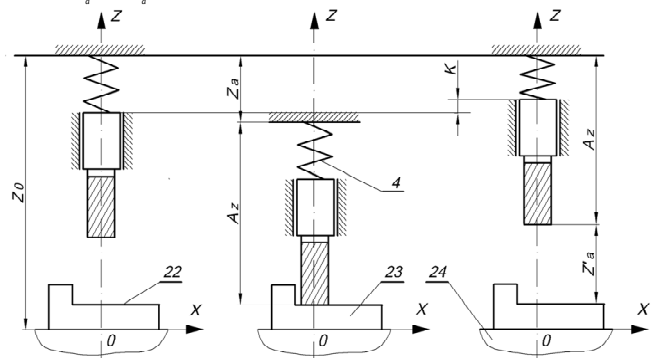

Figure 12. Setting the machining tool outlet according to  $A_z$  outlet

The device operates in the following way.

Before machining and after the tool change, the spindle is in the initial position. The pressure in the hydraulic system, moves the closing axle 5 (Figure 11) to the left, towards the thrust screw, 21, pressing the disk spring, 6, at the same time, the machining tool, 18, remains unclamped. Next, following the steering programme, the spindle, 10, with the tool mounted, moves towards the moving base, 22, of the part (or of the device, 23), pressing the spring, 4, to value  $K$  so as to guarantee the contact of the machining tool with the part (or the device) moving base. Then, in response to a steering signal, the tool is clamped, and the pressure in the hydraulic system drops as a result of valve 9 action. Under the pressure from the disk spring 6, axle 5 moves to the right, mounting the machining tool (Figure 11).

This is the location in which an automatic setting of the tool towards the moving base takes place. Finally, the spindle, following the steering programme, moves either to the initial location ("o") or to the part-processing zone.

The possibility of automatic setting of the tool outlet to the moving base improves and expands the technological possibilities of the CNC machine tool. It reduces the number of necessary operations (e.g. parts setting, which is essential for moving the base) and enables to conduct a series of operations, that were previously carried out on conventional machines using the test passages method, on CNC machines.

#### **A multitask CNC machine tool with an automatic tools fastening device**

In the suggested solution, tool fastening does not involve mechanisms for setting the spindle and sockets. Unlike in previous solutions, there is a simplified control block placed in each tool magazine socket. Those blocks, then, have two functions: setting the tool holder in the tool magazine socket and clamping the tool holder with the spindle's parallel keys. Previous solutions lacked the possibility of controlling the presence of the socket in the spindle. The tool change, there, takes place in certain spindle and socket positions, set with orientation mechanisms. At the same time, the tool holder should be in the spindle for the tool-changing device to operate. Setting the first device manually lowers the level of a CNC machine automation. The presented device both changing tools and setting the magazine may be fully automated, for the tool sockets may be located in the tool magazine.

#### **CONCLUSIONS**

The cost and effect analysis, carried out after applying certain CNC machine re-setting time shortening methods, draws the attention to resolving the

question of improving their reliability and efficiency by appropriate structural solutions for devices used in machining.

The analysis of prepared classification of methods for increasing the productivity and elasticity of CNC multi-roles machine tools as well as the analysis of dependence between this elasticity and the level of the retooling automation confirms, that technological methods, constructional particularly, are the optimum solution for increasing the productivity and the reliability of these machine tools.

#### **REFERENCES**

- [1.] BAI Y., JIA X., CHENG Z. Group optimization models for multi-component system compound maintenance tasks. *Eksploracja i Niezawodność – Maintenance and Reliability* 2011; 1(49): 42–47.
- [2.] FAROOQ S, O'BIRIEN C. Risk calculations in the manufacturing technology selection process, *Journal of Manufacturing Technology Management* 2010; vol. 21, 1: 28–49.
- [3.] MAZUREK L., TARANENKO V., ŚWIĆ A.: Klasyfikacja metod zwiększania elastyczności i wydajności wielozadaniowych obrabiarek CNC. *Komputerowo zintegrowane zarządzanie. Tom II, Pod redakcją Ryszarda Knosali. Oficyna Wydawnicza Polskiego Towarzystwa Zarządzania Produkcją, Opole, 2008, s. 133-142.*
- [4.] MAZUREK L., TARANENKO V., ŚWIĆ A.: Metod of setting the CNC machine tool. *Materiały międzynarodowej naukowo-technicznej konferencji „Progressivnyje napravlenija razvitiia maszino– priborostroitelnykh otraslej i transporta” 14-18 maja 2007 Sevastopol, 2007, c. 50-52*
- [5.] MAZUREK L., TARANENKO V., ŚWIĆ A.: Methods of setting the machining tools on a multitask CNC machines. *Acta Mechanica Slovaca, Journal published by Faculty of Mechanical Engineering, the Technical University in Kosice, 2-A/2007, Rocnik 10. s. 403-406*
- [6.] ŚWIĆ A., MAZUREK L.: Modeling the reliability and efficiency of flexible synchronous production line. *Eksploracja i Niezawodność – Maintenance and Reliability* 2011, 4 (52), s. 41 – 48.
- [7.] ZAWADZKA L., *Współczesne problemy i kierunki rozwoju elastycznych systemów produkcyjnych. Wydawnictwo Politechniki Gdańskiej, Gdańsk 2007.*



ACTA TECHNICA CORVINIENSIS – BULLETIN OF ENGINEERING



ISSN: 2067-3809 [CD-Rom, online]

copyright © UNIVERSITY POLITEHNICA TIMISOARA, FACULTY OF  
ENGINEERING HUNEDOARA,  
5, REVOLUTIEI, 331128, HUNEDOARA, ROMANIA  
<http://acta.fih.upt.ro>