

¹ Robert ABLINGER, ² Jörg EDLER, ³ Martin MORTSCH

BASIC RESEARCH IN RPM-SYNCHRONOUS NONCIRCULAR GRINDING

¹ GRAZ UNIVERSITY OF TECHNOLOGY, INSTITUTE OF PRODUCTION ENGINEERING, KOPERNIKUSGASSE 24, 8010 GRAZ, AUSTRIA

ABSTRACT: With conventional noncircular grinding the uneven shape of workpieces is created by pendular movement of a round grinding disk. In contrast with rpm-synchronous noncircular grinding the workpiece is machined with an unround grinding disk. In process the workpiece and the tool are turning with a certain rpm-ratio. With this special method it is possible to machine several types of unround shapes (e.g. all cams of a camshaft) with just one step of positioning. This paper is focused on basic research in rpm-synchronous noncircular grinding. It shows which possible applications this method offers and also their limits.

KEYWORDS: rpm synchronous, noncircular grinding, unround grinding, contour grinding, unround workpiece

INTRODUCTION

With conventional noncircular grinding the uneven shape of workpieces is machined with a round grinding disk. The machine slide, where the grinding disk is mounted, moves along the x-axis in synchronization to the c-axis. The c-axis is equal to the rotation axis of the workpiece (Figure 1). One disadvantage of this process is the acceleration and deceleration of enormous masses. In sum grinding disk, support, spindle and engine often weigh more than one ton. That causes an enhanced attrition of drive components such as the thread spindle of the x-axis and affects lifetime and maintenance intervals. Furthermore the energy consumption of the grinding process is inefficient and the heat admission affects negatively on machine precision. The inertia of the moved parts restricts the maximum value of velocity, acceleration and lurch and imitates the grinding performance. In addition to that several unround shapes can just be machined in sequence.

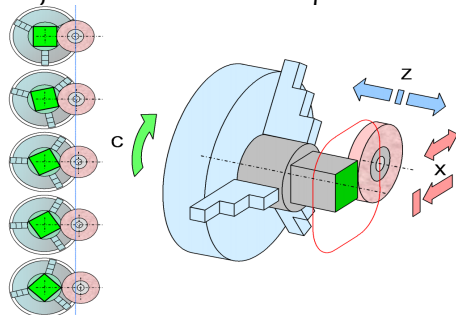
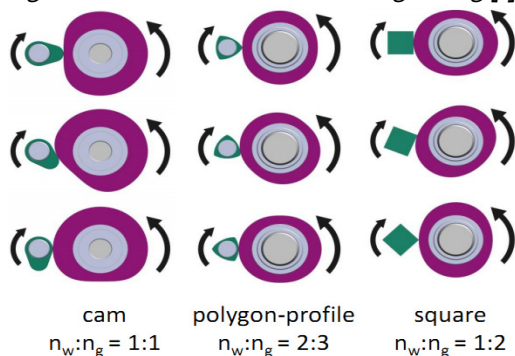

Figure 1 – Conventional noncircular grinding [1]



cam polygon-profile square
 $n_w:n_g = 1:1$ $n_w:n_g = 2:3$ $n_w:n_g = 1:2$

Figure 2 – Examples of workpieces with different geometric shape

With rpm-synchronous noncircular grinding the workpiece is machined with an unround grinding disk. In process the workpiece and the tool are turning with a certain rpm-ratio and the unroundness is transferred from the grinding disk to the workpiece. Rpm-ratio has not imperatively to be 1:1. Figure 2 shows the process of different workpieces with different rpm-ratios.

This method needs only a feed motion and no pendular movement. Therefore the whole grinding machine can be built significantly more compact what has great benefit to machine costs. Another big advantage of this special method is that a couple of round and unround shapes can be machined with only one feed motion. Figure 3 shows how all cams of a camshaft are machined at the same time. The bearing seats could also be machined within this step if the set of grinding disks would be extended with round disks. In addition to shorter process times there is also the positive effect that this twisted assembly of grinding disks is completely balanced.

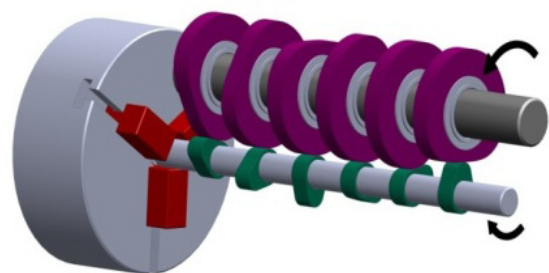

Figure 3 – Multiple machining of multi contours

THEORETICAL BASICS

As one possible solution for unround grinding Dieter Lehmann suggested in 1978 a grinding machine which has an unround grinding disk [2]. The workpiece shape is transferred from a master cam (unround diamonded dressing tool) to the grinding disk and furthermore to the machined workpiece (Figure 4). The speed of rotation is synchronized and the dressing tool has the same profile as the workpiece to be machined. To manufacture such a device there are two options: positive-process and negative-process. At positive-process an unround metal basic body with the

same shape like the workpiece is coated with a layer of diamond grains in a galvanic process.

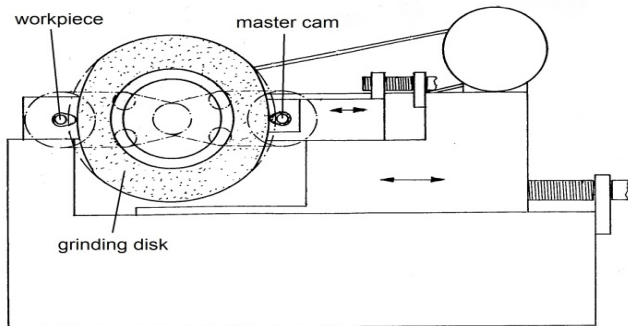

Figure 4 – Grinding machine with unround grinding disk [2]
 This procedure is economic and can be realized in short time. One disadvantage is the spread in size of the diamond grains that directly influences the tool's precision. Therefore the positive-process is mainly used for prototyping. In contrast negative-process is substantial more precise. There is a form ring with a corresponding hollow space which is diamonded on its surface. Afterwards this ring is grounded. Advantageously master cam and workpiece are turning twice fast as the grinding disk. That ensures that the balance of the disk geometry is independent from the geometry of the workpiece (Figure 5).

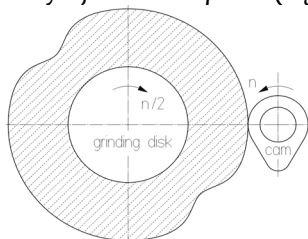

Figure 5 – Balanced grinding disk

The feed motion in radial direction takes place by reduction of the distance between disk- and workpiece axis. Special benefit of this concept is the ability to machine several shapes with one set of disks and only one movement of positioning. Parallel processing of all round and unround shapes makes this grinding machine extremely productive. One disadvantage of the described machine is the assigned rotating dressing tool for the grinding disk which is similar to the geometry of workpiece. Changes in the geometry of the workpiece can only be realized with complex changes in the geometry of the dressing tool. An alternative to the shaped dressing tool is the use of a cylindrical dressing tool which moves in radial direction by a steering cam containing the workpiece geometry (Figure 6). This is another way to shape an according unround grinding disk.

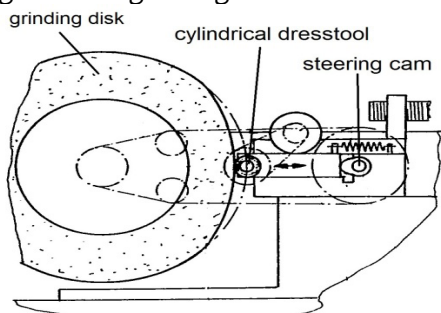

Figure 6 – Steering cam [2]

The dissertation from Holger Eichhorn [3] shows the technological process maturity and practical applicability of rpm-synchronous noncircular grinding and was verified and documented by a lot of experiments. Based on test results the capability of the process and applications where discussed and evaluated.

The invention from Roland Schmitz [4] deals with machining of workpieces with concave shapes. At traditional unround grinding with round disks its outer diameter is limited by the smallest concave radius in workpiece shape. In contrast the usage of unround disks and rpm-synchronization between components makes it possible to use disks with a greater radial extension (Figure 7). Further on an option is shown, how radial grinding forces can be balanced by the usage of 2 disks.

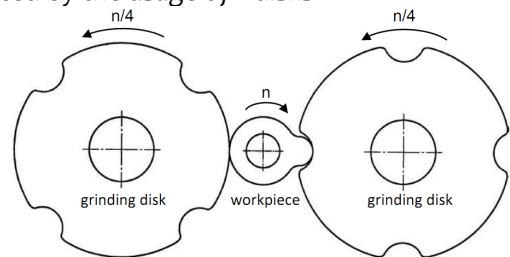

Figure 7 – Cam with concave shape [4]

DEVELOPMENTS AND ANALYSIS. SOFTWARE DEVELOPMENT

Compared with pendular grinding where the curve of the disk center has to be calculated rpm-synchronous noncircular grinding requires that the corresponding unround disk shape has to be calculated. This shape depends on workpiece profile, rpm-ratio and distance between axis of workpiece and disk.

An explicit solution can only be deduced for special rpm-ratios and workpiece profiles. In general the needed geometry of grinding disk can just be found point wise using approximation procedures. To automate this computation and to design additional user-friendly functions at the institute of production engineering from TU-Graz special software for rpm-synchronous noncircular grinding was developed in Matlab. The modules with a high claim on computational power are written in "C" and implemented in the main program. The graphical user interface is designed to operate the program with a SIEMENS SINUMERIK 840D control (Figure 8). This requires the knowledge of function of all 16 control buttons situated on the control panel.

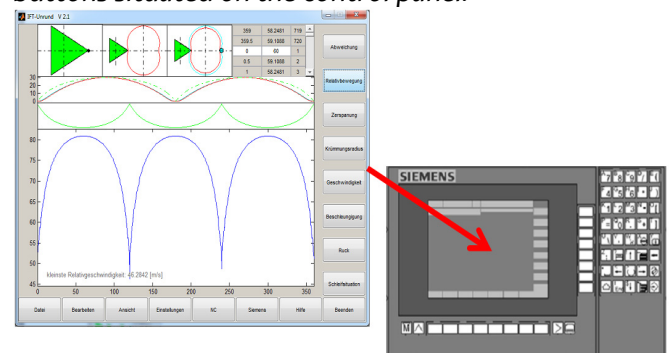

Figure 8 – Graphical user interface

Besides the main function, the computation of the disk profile, three other functions are important:

- Computing of relative velocity between workpiece and grinding disk in point of contact
- Computing of possibly deviations at machined workpiece
- Computing the dressing kinematics

RELATIVE VELOCITY BETWEEN WORKPIECE AND GRINDING DISK

At traditional unround grinding rpm and radius of workpiece normally are essentially smaller than rpm and radius of the grinding disk. To calculate the cutting speed v_c only the velocity of disk's perimeter v_g is considered:

$$v_c = v_g = d_g \cdot \pi \cdot n_g$$

At rpm-synchronous noncircular grinding, where rpm of workpiece is essentially higher, the influence of workpieces perimeter speed v_w to relative velocity often cannot be unattended. To estimate the influence of high workpiece-rpm an example is calculated below.

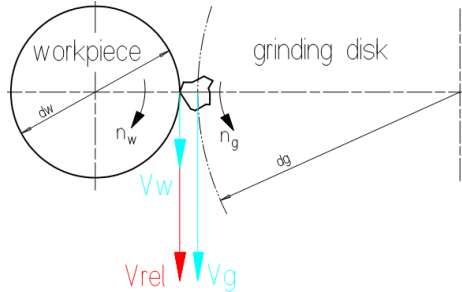

Figure 9 – Relative velocity

According to Figure 9 the equation for relative speed for direction grinding is:

$$v_{rel} = v_g - v_w = d_g \cdot \pi \cdot n_g - d_w \cdot \pi \cdot n_w \quad (2)$$

The diameter ratio is for example $d_g:d_w=10:1$ (e.g. 500mm:50mm). Using a rpm-ratio of $n_g:n_w=1:1$ this will result a relative speed of 90% of disk's perimeter speed v_g . Using common rpm- and diameter-ratios relative speed may be enough if speed directions of workpiece and disk's perimeter are aligned.

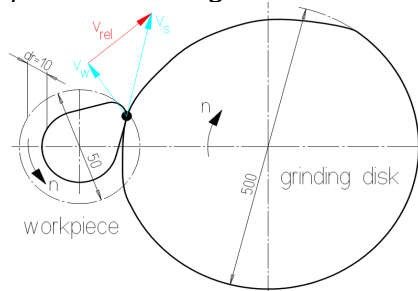

Figure 10 – Unround workpiece and grinding disk

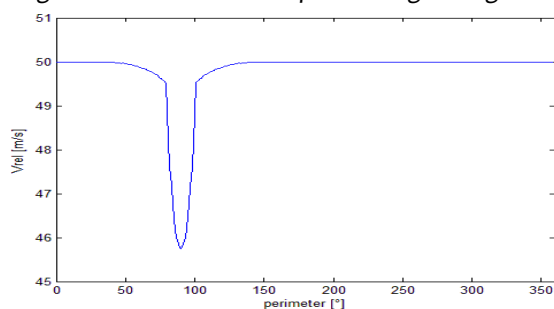

Figure 11 – Relative speed on the perimeter of the grinding wheel

If the unroundness from the surface of the workpiece and the grinding wheel is being accounted, then the relative speed varies in the point of contact. Figure 10 shows a cam, which has a radial change of the diameter with a value of $d_r=10$ mm. This causes a relative speed on the perimeter of the grinding wheel. Its value over the perimeter of the grinding wheel is shown in Figure 11.

MACHINING VOLUME ON THE PERIMETER OF GRINDING WHEEL

The change of the grinding wheel radius does not only cause a variation of the relative speed of the perimeter of the grinding wheel, it also causes a modification of the machining volume. This modification causes an unbalanced abrasion of the grinding wheel. Areas of the grinding wheel with a high machining volume will have a higher abrasion than areas with a lower machining volume. These irregularities can be reflected in the form of dimensional inaccuracies on the grinded surface of the workpiece. To avoid this effect the dressing intervals should be shortened.

DEVIATIONS IN GEOMETRY ON MACHINED WORKPIECE

Without an additional movement in x-direction, especially at counter direction grinding, not all workpiece profile can be machined. Figure 12 shows the process of a triangular shape. The whole contour of the grinding disk just machines the edges of the workpiece. On the plane shape of the triangle there is no contact with the tool. The machined workpiece differs in that area from the target shape.

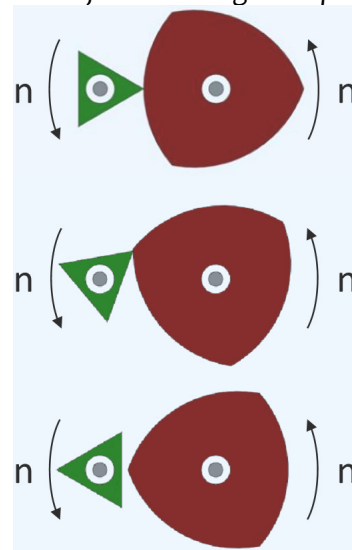

Figure 12 – Counter direction grinding

DRESSING OR MANUFACTURING AN UNROUND GRINDING DISK

With rpm-synchronous noncircular grinding a pendular movement is no longer needed just one movement of positioning is necessary. In that case an unround grinding disk is essential for machining unround workpieces. Stationary dressing tools like diamond slabs cannot be used. The needed support movements would exceed the common kinematic limit values. Besides an unround diamonded dressing tool another option for manufacturing unround grinding disks is the usage of an appropriate metal basic body coated with CBN-grains in a galvanic process. As several coating layers are required the precision decreases with every additional layer. Such a

disk is immediately ready for operation. When the disk is attrited no dressing is needed because it can be coated again.

Apart from the shaped dressing tools there is the option to dress the disk with a round and driven diamond wheel (Figure 13).

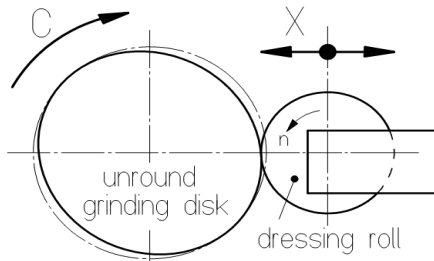

Figure 13 – Flexible dressing with a round diamond wheel
The dressing wheel oscillates in x-direction in synchronization to the disk turning. Thus it is possible to create various disk profiles very flexible. Because the dressing wheel is driven the needed relative velocity between the grinding grains and the dressing diamond will not only be influenced by the disk speed but also by the speed of the dressing wheel. Therefore the disk speed can be chosen small not to override the acceleration limit of the x-axis. This concept is similar to traditional unround grinding but instead of an unround workpiece a grinding disk is dressed by pendular movement.

UNBALANCE FORCE

When the center of gravity of a part is not congruent with its rotation axis an out of balance would be generated. The unbalance force depends on the mass of the workpiece, the angular speed and the distance between the center of gravity and the rotation axis:

$$F = m \cdot r \cdot \omega^2 \quad (3)$$

As the force increases quadratic with the angular speed, the unbalance has to be compensated at high spindle speed with counterweights.

CONCLUSIONS

To ensure an efficient grinding process the relative speed between the acting partners in their contact area should be as large as possible. It is possible to raise spindle speed or radial differential expansion between grinding disk and workpiece. The dimension of the diameter of a grinding disk is limited by the working chamber of the grinding machine. It should be considered that it is often impossible to produce exact workpieces with counter direction grinding if the radial differential expansions of the workpiece is too large. In comparison with same direction grinding it is possible to produce concave workpieces with a grinding disk which has a larger diameter. To increase the flexibility of the grinding machine it should be equipped with a dressing support on which a powered diamond wheel is mounted (Figure 14).

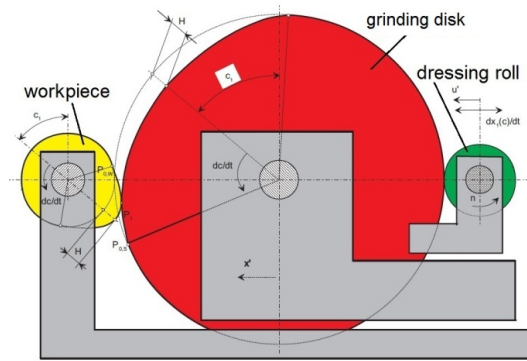

Figure 14 – Grinding machine with a dressing support [5]
With such a grinding machine it is possible to dress different shapes of grinding disks. In comparison with the traditional unround grinding operation the rpm-synchronous noncircular grinding also needs a reciprocating movement for the machining. But it is only necessary to dress the grinding disk after a certain number of machining cycles. Furthermore the moved mass of the dressing support is much lower than the mass of a moved grinding support. In the beginning it was necessary to fix the ratio with a mechanical gear between the axis of rotation from the workpiece and the grinding disk. Nowadays the ratio between these two axis can flexibly have any value with the use of an electronic gear. Using rpm-synchronous noncircular grinding costs in batch production can be reduced. Either with shorter process times because of machining several shapes with one set of grinding disks or the usage of a simpler hence more cost-effective grinding machine.

REFERENCES

- [1] Zuderstorfer, G.: KelPoly – Software für das Unrundscheifen, Dissertation, TU-Graz, Graz, 2006.
- [2] Lehmann, D.: Schleifmaschine, Patent DE2810562C2, Deutsches Patent- und Markenamt, München, 1978.
- [3] Eichhorn, H.: Drehzahlsynchronisation der Wirkpartner beim Abrichten und Schleifen, Dissertation, TU-Berlin, Berlin, 1997.
- [4] Schmitz, R.: Vorrichtung zum Schleifen von Nocken einer Nockenwelle, Patent application DE102008061271A1, Deutsches Patent- und Markenamt, München, 2008.
- [5] Schmid, A.: Moderne Produktionstechniken, Lecture notes, TU-Graz, Graz 2010.

