



<sup>1</sup>. Emmanuel T. OLODO, <sup>2</sup>. Edmond C. ADJOVI,  
<sup>3</sup>. Léopold G. GBAGUIDI AISSE

## DESIGNING OF A COMPOSITE FOLDED MEMBRANE BY A DEVELOPABLE MEMBRANE WITH PARABOLIC GUIDELINES OF ANY ORDER

<sup>1-3</sup>. Ecole Polytechnique d'Abomey-Calavi (EPAC), Department of Civil  
Engineering/University of Abomey-Calavi (UAC), Cotonou, BENIN

**Abstract:** The geometric modeling of a folded composite membrane using method of approximation of a folded composite membrane by a developable surface with parabolic guidelines of any order is an aim of this work. This approach is carried out on a one-way expandable composite membrane with thermosetting polyester matrix reinforced by fiberglass. The geometric model is done in two steps: first one replaces the membrane of reference by a system of developable membranes from which then plane quadrilaterals arranged in a well-defined manner are constructed. This need the establishment of mono parametric equation of the family of the plans and the equation of the cuspidal edge of the developable surface basing on which it is carried out the development of algorithms for the construction of the folded composite membrane and that of the developed of the twisted membrane.

**Keywords:** twisted membranes, folded composite membrane, developable surface

### INTRODUCTION

The twisted membranes belong to the family of developable surfaces whose principal advantage as one knows it resides in their capacity to be spread on a plan without distortion lengths, tearing and crumpling. The applications of developable surfaces in industrial circle are varied. Indeed, the structures whose surface is developable are simply manufactured by folding of their developed form, cut out in a sheet of material. This process is used for example in shipbuilding for the manufacture of the hulls of boat [1]. In the field of the civil engineering and architecture, developable surfaces are generally regarded as a technical method for realization of complex forms. However, the study suggested in [2] show that they can be used like aesthetic tools with whole share.

The current evolution of technology brings to carry out increasingly complex projects, expensive and subjected to increasingly severe constraints of safety. The thin hull belongs to the family of structural surfaces which includes the membranes, folded surfaces and hulls. The hulls with simple or S curve are of everyday usage in structural engineering (engineering mechanical, civil,

shipbuilding, aeronautical, etc). Vis-a-vis the geometrical complication of the majority of the structures membrane, the recourse to models more innovating, robust and fulfilling the requirements of reliable simulation as well as possible, proves to be paramount. The recourse to the material concrete to build 3D surfaces a little lost today with the profit of other materials the such composites. In addition, a complete modeling 3D with voluminal finite elements causes costs of prohibitory calculations as well as numerical problems of blockings for the mean structures.

An alternative resides in the development of a macroscopic model which consists in replacing a developable composite membrane by a system of plane quadrilateral elements i.e. a curved membrane by a folded surface. This approach is justified especially for developable surfaces bus by definition they are made of a mono parametric family of tangent plans on these surfaces according to the right generatrices.

### FORMULATION OF THE PROBLEM AND METHOD

In this work, one proposes a macroscopic model allowing the simulation of working of a composite

on a macroscopic scale by using a geometrical modeling much simpler than those of the literature like that proposed in [3]. This model suggested is based on a method of approximation of a composite folded membrane by a twisted surface with parabolic guidelines of any order.

**MATHEMATICAL ASPECTS**

The modeling of developable surfaces is a complicated problem, especially if one does not force the surface to be regular of class  $C^2$ . Developable surfaces are isometric surfaces in the plan. The theorem of Minding states that two surfaces having even constant Gaussian curve are isometric. In this case, the theorem egregium indicates that the curve of Gauss of a developable surface is inevitably null in any point.

In general, it is more convenient to define a developable surface by a vector equation set of the shape:

$$\vec{r} = \vec{r}(u, v) = x(u, v)\vec{i} + y(u, v)\vec{j} + z(u, v)\vec{k} \quad (1)$$

or by parameterized form:  $x=x(u,v)$ ,  $y=y(u,v)$ ,  $z=z(u,v)$  which may be one of the types:

$$z = z(u, v), \quad (2)$$

$$M(x, y, z) = 0, \quad (3)$$

The expression (2) defines the coordinate  $z$  as a direct parameterization and the expression (3) as a dual parameterization where not all the plans are parallel and the family of plans does not form a beam, that is, there is not a right common to all these plans.

Discretization: There is not discrete equivalent of the Gaussian curve, several expressions were proposed besides [4,5,6]. Consequently, there is not single solution to discretize a developable surface. The method described in [7] for example is based on the representation of tangent developable surfaces. The cuspidal edge is discretized and becomes a polygon.

Another solution consists in defining a developable surface as a surface being able to be put flat without being stretched. While following this step, the models of the type "band" were proposed. They consist of an articulated assembly of plane elementary forms forming a band. In [8], the elementary forms are triangles. It is then possible to obtain developable approximations of surfaces which are not it. Same manner one can choose plane quadrilaterals to compose a band. This

process is used for example in [9]. Limiting surface obtained is then developable.

**GEOMETRICAL MODEL SUGGESTED**

Let us consider a twisted surface whose curved generatrices are plane parabolas of order  $m$  and  $n$ :

$$\begin{aligned} x &= 0, \quad x = 1, \\ y &= az^n \quad \text{and} \quad y = bz^m. \end{aligned} \quad (4)$$

In this case, the parametric mono equation of the family of the plans will have the following form:

$$M = (n-1)(l-x)\beta^n + n\beta^{n-1}(x\gamma - zl) + \frac{1}{a}(ly - bxy^m) = 0 \quad (5)$$

Where  $\beta=z$ , parameter of the parabola of the plan  $x=0$  and  $\gamma=z$ , parameter of the other parabola. The parameters  $\beta$  and  $\gamma$  are bound by the following relation [10]:

$$\gamma^{m-1} = \frac{an\beta^{n-1}}{bm} \quad (6)$$

By introducing the formula (6) into the equation (5) we will have:

$$M = M(x, y, z, \beta) = 0.$$

The right generatrix of the twist passes by the point  $\beta=z$  of parabola of order  $n$  and by the corresponding point  $\gamma=z$  of parabola of order  $m$ . A twisted surface is completely given by its cuspidal edge whose definition is sufficient for the construction of its developed and that of the folded surface built starting from twisted surface [11].

For considered twisted surface, when  $m=n$ , we obtain the equation of the cusp edge in the form:

$$z = 0, \quad y = 0, \quad x = \frac{l}{(1 - \sqrt[n]{a/b})}$$

I.e. we have a cone if  $a \neq b$  or a cylinder if  $a=b$ . When  $m \neq n$ , we obtain the equation of the cuspidal edge by the resolution of the following system:

$$M = 0, \quad \frac{\partial M}{\partial \beta} = 0, \quad \frac{\partial^2 M}{\partial \beta^2} = 0,$$

For example for  $m=2$ ,  $n=4$  we find:

$$x = \frac{bl}{b - 6a\beta^2}, \quad y = -\frac{2a^2\beta^6}{b - 6a\beta^2}, \quad z = -\frac{4a\beta^3}{b - 6a\beta^2} \quad (7)$$

Let's assume that:  $a=0.5$ ;  $b=1$ ;  $l=5$ ;  $m=2$ ;  $n=4$ . The formula (2) will take the following form:

$$M = (2\beta^6 - 3\beta^4)x + 10y - 20\beta^3z + 15\beta^4 = 0, \quad (8)$$

and of the relation (6) we will have  $\gamma = \beta^3$ .

**RESULTS AND DISCUSSIONS**

The twisted surface with parabolic guidelines of order  $m=2$ ,  $n=4$  and its corresponding cuspidal edge are shown in figure 1. From equation (7) one can determine the coordinates of the remarkable point for (not of return):  $\beta=0$ ,  $x=1$ ,  $y=z=0$ ; for  $\beta=\sqrt[3]{b/6a}$  there is a rupture of the cuspidal edge.

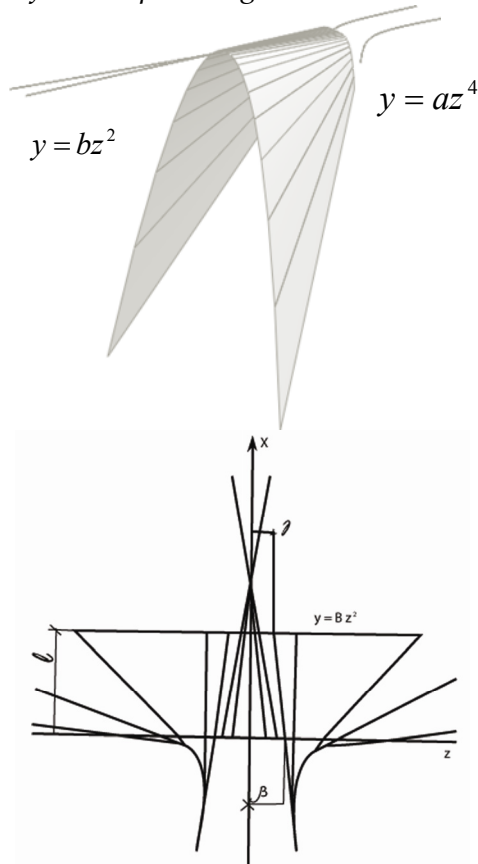

Figure 1. Developable surface and its cuspidal edge  
**ALGORITHM OF CONSTRUCTION OF FOLDED SURFACE**

The algorithm of construction of the folded surface on the basis of given twisted surface is studied in [12]. Let us build the developed of the folded surface (figure 2), tangent to the given twist according to the right generatrix when  $\beta = 0$ ;  $\beta = 0.5$ ;  $\beta = 1$ ;  $\beta = 1.5$ .

We obtain the coordinates of the angular points of the folded surface as being the components of the points of intersection of three plans. Two plans will be given by two sides close to the folded surface which one can obtain by the mono parametric equation of the family of the plans (5) by fixing two parameters  $\beta$ . The third plan will be that to which belongs the corresponding curved guideline of the

twist, for example the plan  $x=0$  or the plan  $x=l=5$ . So, we shall have:

$$M(\beta = 0) = 10y = 0,$$

$$M(\beta = 0.5) = -0.15625x + 10y - 2.5z + 0.9375 = 0,$$

$$x = 0,$$

$$A(x, y, z) = A(0; 0; 0.375),$$

$$M(\beta = 0) = 10y = 0,$$

$$M(\beta = 0.5) = -0.15625x + 10y - 2.5z + 0.9375 = 0,$$

$$x = 5,$$

$$A'(x, y, z) = A'(5; 0; 0.062),$$

$$M(\beta = 0.5) = -0.15625x + 10y - 2.5z + 0.9375 = 0,$$

$$M(\beta = 1) = -x + 10y - 20z + 15 = 0,$$

$$x = 0,$$

$$B(x, y, z) = B(0; 0.107; 0.8)$$

$$M(\beta = 0.5) = -0.15625x + 10y - 2.5z + 0.9375 = 0,$$

$$M(\beta = 1) = -x + 10y - 20z + 15 = 0,$$

$$x = 5,$$

$$B'(x, y, z) = B'(5; 0.12; 0.56)$$

$$M(\beta = 1) = -x + 10y - 20z + 15 = 0,$$

$$M(\beta = 1.5) = 7.59x + 10y - 67.5z + 75.94 = 0,$$

$$x = 0$$

$$C(x, y, z) = C(0; 1.04; 1.28)$$

$$M(\beta = 1) = 0; M(\beta = 1.5) = 0; x = 5, \quad C'(5; 3.32; 2.18).$$

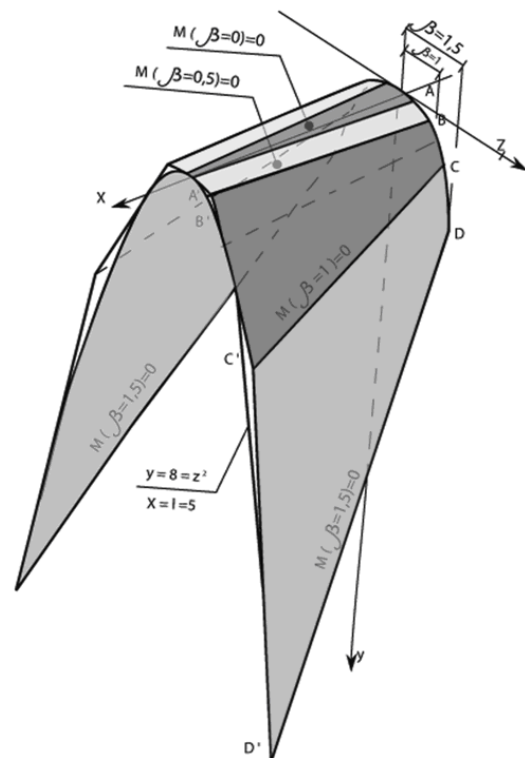

Figure 2. Folded surface obtained from the developable surface  
In figure 2 one shows obtained folded surface. The side  $DD'$  is formed by the right generatrix of the twist when  $\beta = 1.5$ ,  $y = \beta^3 = 3.375$ , thus coordinates

of the point D' will be  $D'(5; 11.39; 3.375)$  and those of the point D will be  $D(0; 2.53; 1.5)$ .

Having determined the coordinates of the angular points of folded surface, it is easy to calculate the linear and angular values necessary to construction of developed folded surface (figure 3).

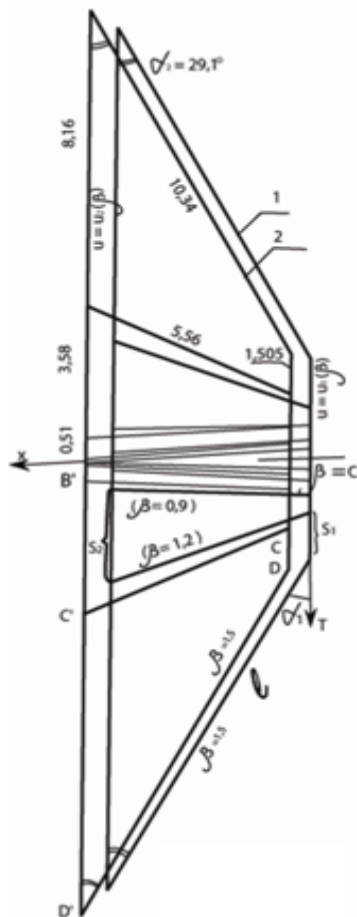

Figure 3. Developed folded surface. 1-Developed of the twist; 2-Developed of the folded surface

**ALGORITHM OF CONSTRUCTION OF DEVELOPED TWIST**

Let us build considered developed twist by the method suggested in [11]. Knowing that the vectorial equation of a twisted surface is written in the following form:

$$\vec{r}(u, \beta) = x\vec{i} + y\vec{j} + z\vec{k} + u \frac{x'\vec{i} + y'\vec{j} + z'\vec{k}}{\sqrt{x'^2 + y'^2 + z'^2}},$$

with  $x = x(\beta), y = y(\beta), z = z(\beta)$  - parametric equation of the cuspidal edge (4) and  $u, \beta$  - curvilinear coordinates of the twist,  $|u|$  - the distance between the cuspidal edge and any point parallel to taken the tangent with the cuspidal edge, we obtain the equations of the guideline parabolas:

$$u_1 = \frac{1}{b - 6a\beta^2} \sqrt{b^2 l^2 + (ab\beta^4 - 4a^2\beta^6)^2 + (b\beta - 2a\beta^3)^2},$$

$$u_2 = \frac{1}{b - 6a\beta^2} \sqrt{36a^2 l^2 \beta^4 + (6a^2\beta^6 - \frac{24a^3}{b}\beta^3)^2 + (6a\beta^3 - \frac{12a^2\beta^3}{b})^2}$$

where  $u_1 = u_1(\beta)$  - equation of the parabola of order  $n=4$ ,  $u_2 = u_2(\beta)$  - equation of the parabola of order  $m=2$ .

The length of the right generatrix between the guideline parabolas is determined by the following formula:

$$t = u_2 - u_1.$$

The angle formed by the parabola and the right generator can be calculated by the following formula:

$$\cos \alpha_i = \frac{F + u'_i}{[u_i'^2 + 2Fu'_i + B_i^2]^{1/2}} \text{ with } i=1;2.$$

The lengths of the extreme curves between the corresponding right generators are determined by the formula:

$$S_i = \int_{\beta_1}^{\beta_2} \sqrt{u_i'^2 + 2Fu'_i + B_i^2} d\beta, \text{ with } i= 1 ; 2.$$

In the two last formulas expressions  $F = \vec{r}_u \vec{r}_\beta$ ,  $B^2 = \vec{r}_\beta \vec{r}_\beta$  [11] are the coefficients of the first quadratic form of a surface. The subscripts of B indicate that these coefficients must be taken with  $u = u_i (i=1 ; 2)$ .

Let us build developed twisted surface for which the mono parametric equation of the family of the plans is obtained in the form (8)). The values of  $t, a_i, S_i$  will be given in the interval  $0 \leq \beta \leq 1.5$  with spacing  $\Delta\beta=0.3$ . It is easy to execute these calculations on computer. The results of calculations are reported to table 1.

Developed twisted surface is shown in figure 3. One can notice that for the determination lengths of the extreme curves between the corresponding right generatrices, one uses the following formula of analytical geometry [13]:

$$S = \int_z^{z+\Delta z} \sqrt{1 + (\frac{dy}{dz})^2} dz,$$

For our case where  $n=4, m=2$  (see formula (4)), it takes the form:

$$S_1 = \int_z^{z_1+\Delta z_1} \sqrt{1 + 16a^2 z^6} dz, \quad z_1 = \beta, \quad (n = 4)$$

$$S_2 = \frac{z}{2} \sqrt{1 + 4b^2 z^2} + \frac{1}{8b^2} \ln \left| z + \frac{1}{2b} \sqrt{1 + 4b^2 z^2} \right|_{z_2}^{z_2+\Delta z_2} \quad (m=2).$$

Table 1. Results of calculation of the lengths of the extreme curves

$\beta$	$\gamma=\beta^3$	$t$	$\alpha_1$	$\alpha_2$	$S_1$	$S_2$
0	0	5.0	90°	90°	0.3000	0.0203
0.3	0.027	5.01	-86.88°	-86.88°	0.3077	0.1498
0.6	0.216	5.01	-86.95°	-86.95°	0.4046	0.6207
0.9	0.729	5.01	89.19°	89.19°	0.7726	2.5618
1.2	1.728	5.39	68.01°	68.01°	1.5253	8.4883
1.5	3.375	10.34	29.10°	29.10°		

The results obtained show that the method of approximation proposed as part of this work can be used to get a complete and relevant solution with a time of calculation on computer, by far much lower than the finite element method. Developable composite membranes' modeling is a complicated problem and sometimes inextricable therefore that it does not impose on the surface to be of certain regularity. So, the possibility of the replacement of a developable composite surface by a folded surface lets you extend the fields of application of these membranes because with the increase in the number of edges (boundaries), one could get a folded structure identical to the expandable membrane of reference. This offers new perspectives to the design of a new variety of folded composite structures.

The theory concerning working of the composite structures with developable form was the subject of a number of studies for example in [14]. In a general way, concerning the composites, for the production of developable forms one often uses thermo-hardening resins whose reinforcements are presented in the form of continuous chechmates i.e. distributed tablecloths in a one-way way. Indeed, the composite membrane object of our study is reinforced resin polyester with one-way fiberglass bus today, only the macroscopic approaches make it possible to simulate working of the composite membranes of this class. The lower scale models make it possible as for them studied the behavior of a reinforcement starting from the assembly of its elementary components. However, the macroscopic scale considers the reinforcement as a continuous material whose behavior is closely related to its internal structure but this one does not appear in an explicit way in modeling. The majority of the

digital simulations on this scale use a continue approach [15, 16].

**CONCLUSIONS**

In this work we can retain the following:

- It's proceeded to the study of developable composite membrane with parabolic guidelines as two plan paraboles of order  $m$  and  $n$ :  $x=0, y=az^n$  and  $x=l, y=bz^m$ . This developable membrane, it is established the mono parametric equation of family plans and the equation of the cuspidal edge. The cuspidal edge of the developable surface with parabolic guidelines of order  $n=4, m=2$  presents a singular point ( $x=l, y=z=0$ ).

When  $z=\sqrt{\frac{b}{6a}}$ , it has a break from the cuspidal edge.

- It is built the developed of the folded membrane tangent to the developable membrane following four straight generatrixes (figure 2; figure 3).

A method for the construction of the developed of the twisted membrane is developed. Through this approach, we see that with the increase in the number of edges of the folded surface, the dimensions of its developed approximately are very close to those of the corresponding developable membrane. This offers a considerable interest of practical application for the formatting of folded composite membranes.

**REFERENCES**

- [1.] Chu, C. and J.T. Chen, 2007. Characterizing degrees of freedom for geometric design of developable composite Bezier surfaces. *Rob. and Computer-Integr. Manuf.*, 23:116-125
- [2.] Glaser, G. and F. Gruber, 2007. Developable surfaces in contemporary architecture. *J. Math. and the Arts*, 01:59-71
- [3.] Hivet, G., P. Boisse, 2005. Consistent 3D geometrical model of fabric elementary cell. Application to a meshing preprocessor for 3D finite element analysis. *Finite Element in Analysis and Design*, 42(1):25-4
- [4.] Sullivan, J.M., 2008. Curvatures of smooth and discrete surfaces. Springer, *Discrete Differential Geometry*, 38 :175-188
- [5.] Wang, C. and Tang K., 2004. Achieving developability of polygonal surface by minimum deformation: a study of global and local optimization approaches. *The visual computer. Int. J. Comp. Graph.*, 20:521-539

- [6.] Yamauchi, H., S. Gumhold, R. Zayer and H.P. Seidel, 2005. Mesh segmentation driven by Gaussian curvature. *Visual Computer*, 21:649-658
- [7.] Pottmann and J.Wallner, 2001. *Computational line Geometry*, Springer, ISBN 3-540-42058-4, pp.565
- [8.] Wang, C. and Tang K., 2005. Developable triangulations of strip. *Computer-Aid Design & App.*, 2:233-242
- [9.] Liu, Y., H. Pottmann, J. Wallner, Y.L. Yang and W. Wang, 2006. Geometric modeling with conical meshes and developable surfaces. *ACM Trans. Graph.*, 25:681-689
- [10.] Krivoshapko, S.N., 1982. Construction, calculation and application of the developed membranes in the thin-walled structures. *Calculation of the thin walled structures*, Edns. Russian Friendship University, pp. 54-66 (in Russian)
- [11.] Krivoshapko, S.N., 1983. The application of developable surfaces in shipbuilding. *Shipbuilding*, 7:5-7 (in Russian)
- [12.] Krivoshapko, S.N., A.G. Shtykov and V.P. Shabanov, 1982. Replacement of the twisted membranes by plane elements. *Bul. Mil. Eng.*, 2 : 18-21 (in Russian)
- [13.] Badjoria, G.C., 1984. On a method of construction of the developed of a twisted surface. *Shipbuilding*, 9: 37-38 (in Russian)
- [14.] Cheruet, A., 2001. *Analyse et simulation de la mise en forme de composites thermodurcissables*. Thèse de doctorat Université d'Orléans
- [15.] Peng, X.Q., J. Cao, 2005. A continuum mechanics-based non orthogonal constitutive model for woven composite fabrics. *Composites Part A*, 36(6):859-874
- [16.] Thijs Ten, R.H.W., R. Akkerman and J. Huétink, 2007. Large deformation simulation of anisotropic material using an update Lagrangian finite element method, *Computer Method in Applied Mechanics and Engineering*, 196(33-34):3141-3150



**ACTA Technica CORVINIENSIS**  
BULLETIN OF ENGINEERING

**ISSN:2067-3809**

copyright ©  
University "POLITEHNICA" Timisoara,  
Faculty of Engineering Hunedoara,  
5, Revolutiei,  
331128, Hunedoara, ROMANIA  
<http://acta.fih.upt.ro>